

**MODEL LPD 10" - 24"
LOW PRESSURE DROP
125# FLANGED STRAINER**

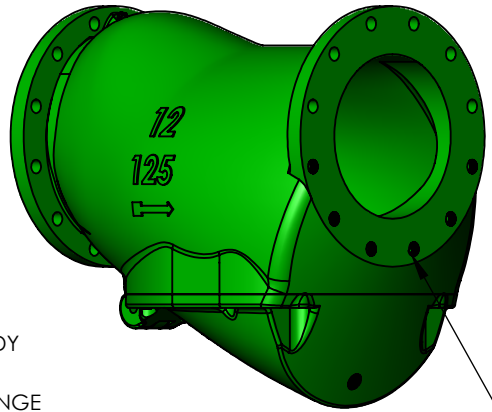
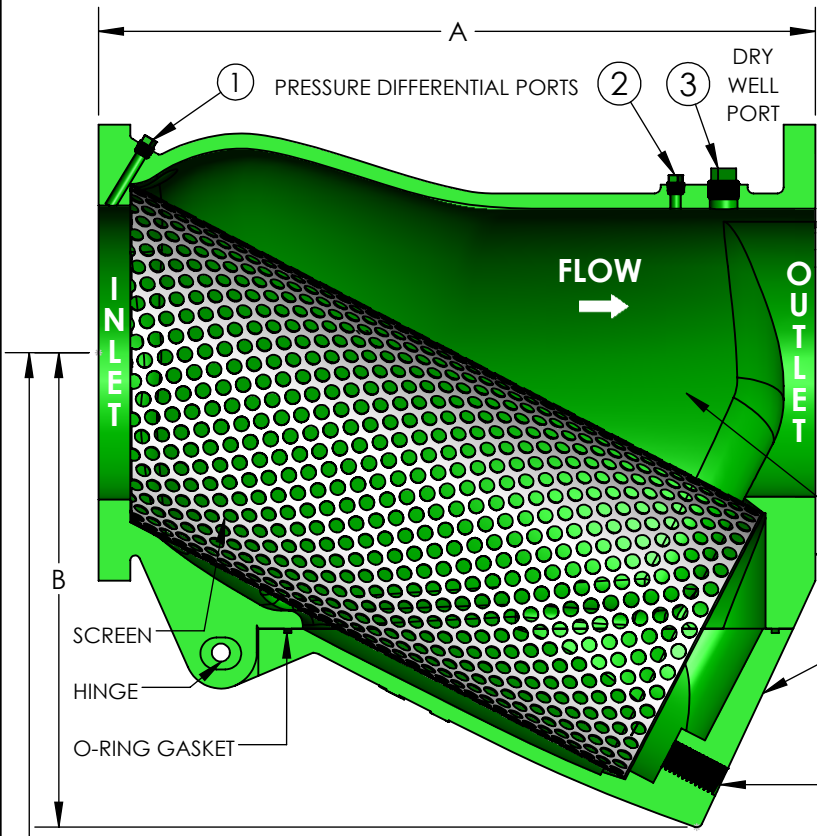

***TAPPED BOLT HOLES**
HALF OF THE BOLT HOLES ON THE OUTLET END ARE TAPPED. SEE TAP SIZE BELOW FOR SIZING. STUDS PROVIDED FOR TAPPED HOLES.

C (CLEARANCE TO REMOVE STRAINER FROM BELOW)
*IF THERE IS NOT ENOUGH CLEARANCE BELOW STRAINER, PRODUCT CAN BE ROTATED 90° AXIALLY TO PROVIDE CLEARANCE OR FOR STEAM APPLICATION TO MINIMIZE CONDENSATE COLLECTION

STANDARD SCREENS

SERVICE	SIZE	PERF
LIQUID	10" - 24"	.125"
STEAM	10" - 24"	.062"

MATERIALS OF CONSTRUCTION
BODY, FLANGES, COVER PLATE - CAST IRON (10"-18")/DUCTILE IRON (20"-24")
SCREEN - 304 STAINLESS STEEL
O-RING GASKET - VITON

OPERATING TEMPERATURE/PRESSURE
WATER, OIL, GAS.....175 PSI @ 150°F
STEAM.....125 PSI @ 350°F

QTY	PART NUMBER	PIPE SIZE		A	B	C	#Cv (GPM)	SCREEN AREA (in ²)	PORT SIZE (NPT)		BLOWOFF SIZE (NPT)	TAP SIZE (UNC)	TAP DEPTH	WEIGHT (LBS)
		INCH	MM						1 & 2	3				
	LPD1000	10"	250	27"	16-5/8"	37-7/8"	2424	745.2	3/8"	1"	2"	7/8"-9	1-1/8"	464
	LPD1200	12"	300	29-7/8"	19-3/4"	43-5/8"	3200	1035.1	3/8"	1"	2"	7/8"-9	1-1/8"	565
	LPD1400	14"	350	33-1/4"	22-1/4"	49-1/2"	N/A	1276.0	3/8"	1"	2"	1"-8	1-1/4"	900
	LPD1600	16"	400	38-3/4"	25-5/8"	58-1/4"	N/A	1750.0	3/8"	1"	2"	1"-8	1-1/4"	1300
	LPD1800	18"	462	43-1/8"	27-1/8"	62-1/4"	N/A	N/A	3/8"	1"	2"	1-1/8"-7	1-1/4"	1700
	LPD2000	20"	508	49-1/2"	30-1/4"	72"	N/A	N/A	3/8"	1"	2"	1-1/8"-7	1-1/4"	2100
	LPD2400	24"	610	55-13/16"	35-7/8"	80"	N/A	N/A	3/8"	1"	2"	1-1/8"-7	1-1/4"	3100

#Cv IS THE FLOW RATE IN GALLONS OF 60°F WATER THAT WILL PASS THROUGH THE STRAINER IN 1 MINUTE AT A 1 PSI PRESSURE DROP.

NSF 372 - LEAD FREE
The wetted surface of this product contacted by consumable water contains less than one quarter of one percent (0.25%) of lead by weight. Material complies with state codes and standards, where applicable, requiring reduced lead content.

CUSTOMER: _____
PROJECT: _____
ENGINEER: _____

3	ADDED SIZE AND WEIGHTS	11/18/2024
REV. 2	REVISED BLOWOFF PLUG NOTE	DATE: 11/29/2023
		2323 W. HUBBARD ST. CHICAGO, IL 60612 TEL: 312-738-3800 FAX: 312-738-0415 WWW.METRAFLEX.COM
MODEL LPD LOW PRESSURE DROP 125# FLANGED STRAINER		
DRAWN BY: JULIANH		DATE: 10/04/2024
APPROVED:		DATE:
SCALE: N/A	DRAWING NUMBER: LPD-10-24	