

# MODEL SEAL WALL PENETRATION SEAL

## MATERIALS OF CONSTRUCTION/DESIGN DATA

TYPE	SEAL MATERIAL	PRESSURE PLATES	BOLTS & NUTS	TEMPERATURE RANGE (°F)
E	EPDM BLACK	GLASS REINFORCED PLASTIC	STEEL ZINC DICHROMATE	-40 TO +250
ES	EPDM BLACK	GLASS REINFORCED PLASTIC	316 STAINLESS STEEL	-40 TO +250
P	NITRILE BLACK	GLASS REINFORCED PLASTIC	STEEL ZINC DICHROMATE	-40 TO +210
PS	NITRILE BLACK	GLASS REINFORCED PLASTIC	316 STAINLESS STEEL	-40 TO +210
HT	SILICONE GRAY	STEEL ZINC DICHROMATE	STEEL ZINC DICHROMATE	-40 TO +400

NOTE: MAX SEALING PRESSURE OF 20 PSIG AND 40 FT. HEAD

ALL DIMENSIONS ARE IN INCHES

## DIMENSIONAL DATA

MODEL #	FREE STATE THICKNESS	FREE STATE LENGTH	EXPANDED STATE THICKNESS	CHORD LENGTH
MS-200	.50	1.75	.62	1.125
MS-275	.62	1.75	.78	.910
MS-300	.71	2.37	.88	1.510
MS-315	.82	2.37	1.03	1.470
MS-325	.94	2.63	1.18	3.100
MS-340	1.05	2.70	1.33	1.575
MS-360	1.29	2.70	1.65	2.106
MS-400	1.43	3.50	1.81	3.625
MS-410	1.48	3.37	1.91	2.598
MS-425	1.13	3.00	1.45	3.625
MS-475	1.62	3.38	1.90	2.625
MS-500	2.37	3.75	2.81	3.860
MS-525	2.18	3.75	2.50	3.860
MS-575	1.81	3.75	2.35	3.100
MS-600	3.20	4.00	4.00	6.000
MS-650	2.76	3.98	3.57	4.160

\*FOR SIZING INFORMATION SEE METRASEAL SELECTION CHARTS

[WALL PENETRATION SEALS](#)

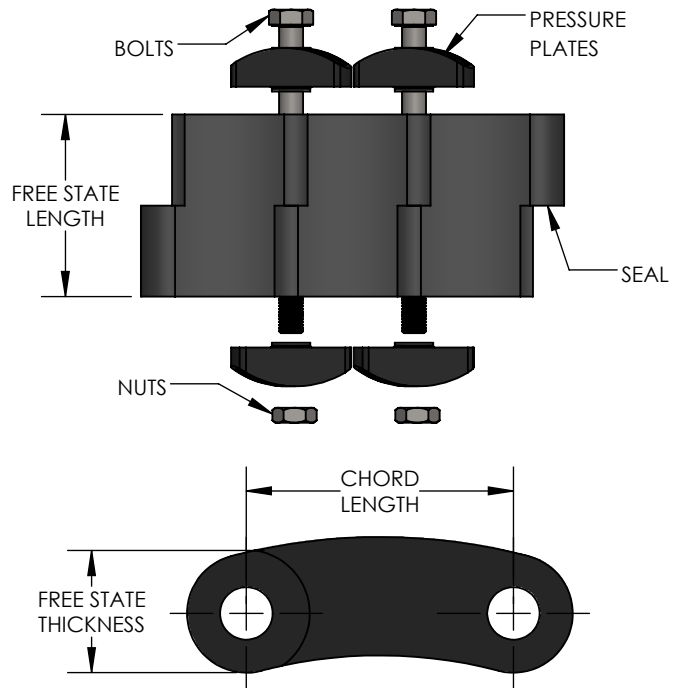
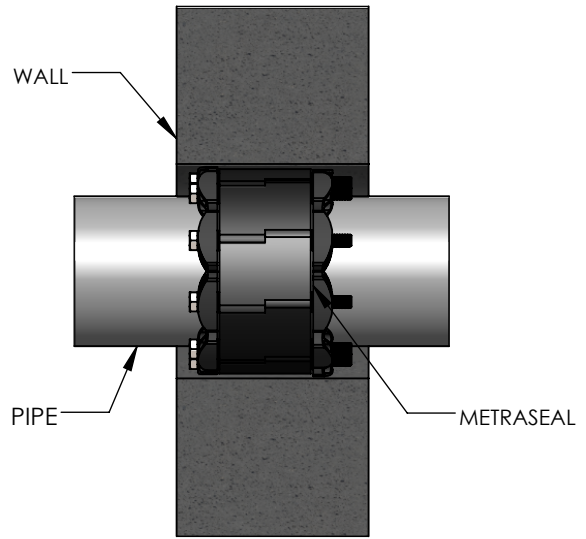

NOMINAL PIPE SIZE & TYPE OF PIPE	PIPE O.D.	INNER PIPE THROUGH A CORE DRILLED HOLE			INNER PIPE THROUGH A WALL SLEEVE			NOTES
		HOLE DIA.	MODEL NO./TYPE	QTY. OF LINKS	SLEEVE I.D.	MODEL NO./TYPE	QTY. OF LINKS	

NSF 372 - LEAD FREE  
The wetted surface of this product contacted by consumable water contains less than one quarter of one percent (0.25%) of lead by weight. Material complies with state codes and standards, where applicable, requiring reduced lead content.

CUSTOMER: \_\_\_\_\_

PROJECT: \_\_\_\_\_

ENGINEER: \_\_\_\_\_

2	FREE STATE LENGTH ADDED	01/06/2025
REV. 1	MS-650 ADDED	DATE 12/27/2018
		2323 W. HUBBARD ST. CHICAGO, IL 60612 TEL: 312-738-3800 FAX: 312-738-0415 WWW.METRAFLEX.COM
<b>MODEL SEAL</b> WALL PENETRATION SEAL		
DRAWN BY: DKISH		DATE: 05/22/2015
APPROVED: ZB		DATE: 05/22/2015
SCALE: N/A	DRAWING NUMBER: SEAL-2	