

**MODEL DSEE, DOUBLESPIHERE
EPDM EXPANSION JOINT, DRILLED BOLT HOLES**

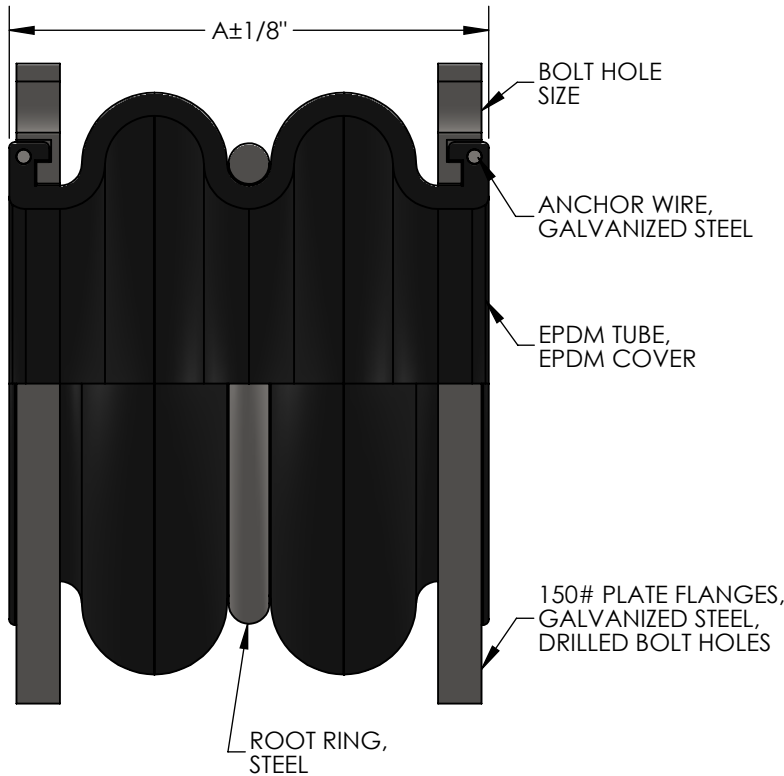

MAXIMUM OPERATING CONDITIONS

TEMPERATURE	PRESSURE (PSI)	
	1" - 12"	14" AND UP
170°	225	125
180°	200	115
190°	175	105
200°	150	95
210°	125	40
220°	100	35
230°	75	25

MAXIMUM WORKING TEMPERATURE 230°F

NOTES:

WWW.METRAFLEX.COM FOR INSTALL INSTRUCTIONS.
JOINT MUST BE INSTALLED AT ITS NEUTRAL LENGTH.
BOLTS MUST BE PROPERLY TORQUED.
NOT SUITABLE FOR STEAM OR VACUUM APPLICATIONS.
IF CONNECTING PIPE IS NOT ANCHORED AND GUIDED,
CONTROL UNITS MUST BE USED.

TO BE FURNISHED WITH CONTROL UNITS:

YES NO

QTY	PART NUMBER	PIPE SIZE		A	AXIAL COMP.	AXIAL EXT.	LATERAL OFFSET	ANGULAR	AXIAL SPRING RATE	LATERAL SPRING RATE	WEIGHT (LBS)	BOLT HOLE SIZE
		INCH	MM									
	DSEE0125	1-1/4"	32	7"	2"	1-1/8"	1-3/4"	40°	135 LBS/IN	154 LBS/IN	8	5/8"
	DSEE0150	1-1/2"	38	7"	2"	1-1/8"	1-3/4"	40°	161 LBS/IN	184 LBS/IN	9	5/8"
	DSEE0200	2"	50	7"	2"	1-1/8"	1-3/4"	40°	194 LBS/IN	246 LBS/IN	10	3/4"
	DSEE0250	2-1/2"	65	7"	2"	1-1/8"	1-3/4"	40°	242 LBS/IN	267 LBS/IN	13	3/4"
	DSEE0300	3"	80	7"	2"	1-3/8"	1-3/4"	40°	290 LBS/IN	289 LBS/IN	14	3/4"
	DSEE0400	4"	100	9"	2"	1-3/8"	1-1/2"	35°	387 LBS/IN	333 LBS/IN	15	3/4"
	DSEE0500	5"	125	9"	2"	1-3/8"	1-1/2"	30°	482 LBS/IN	382 LBS/IN	24	7/8"
	DSEE0600	6"	150	9"	2"	1-3/8"	1-1/2"	30°	578 LBS/IN	433 LBS/IN	33	7/8"
	DSEE0800	8"	200	13"	2-3/8"	1-3/8"	1-3/8"	30°	644 LBS/IN	527 LBS/IN	48	7/8"
	DSEE1000	10"	250	13"	2-3/8"	1-3/8"	1-3/8"	30°	804 LBS/IN	567 LBS/IN	65	1"
	DSEE1200	12"	300	13"	2-3/8"	1-3/8"	1-3/8"	20°	965 LBS/IN	664 LBS/IN	103	1"
	DSEE1400	14"	350	13-3/4"	1-1/2"	1-1/8"	1-1/8"	20°	1025 LBS/IN	783 LBS/IN	128	1-1/8"
	DSEE1600	16"	400	13-3/4"	1-1/2"	1-1/8"	1-1/8"	20°	1085 LBS/IN	900 LBS/IN	158	1-1/8"
	DSEE1800	18"	450	13-3/4"	1-1/2"	1-1/8"	1-1/8"	20°	1132 LBS/IN	995 LBS/IN	180	1-1/4"
	DSEE2000	20"	500	13-3/4"	1-1/2"	1-1/8"	1-1/8"	20°	1204 LBS/IN	1112 LBS/IN	210	1-1/4"
	DSEE2400	24"	600	13-3/4"	1-9/16"	1-3/16"	1-3/16"	20°	1325 LBS/IN	1154 LBS/IN	295	1-3/8"

NSF 372 - LEAD FREE

The wetted surface of this product contacted by consumable water contains less than one quarter of one percent (0.25%) of lead by weight. Material complies with state codes and standards, where applicable, requiring reduced lead content.

CUSTOMER: _____

PROJECT: _____

ENGINEER: _____

REV. 1	REVISED SPRING RATES	DATE 12/11/2024
		2323 W. HUBBARD ST. CHICAGO, IL 60612 TEL: 312-738-3800 FAX: 312-738-0415 WWW.METRAFLEX.COM
METRASPHERE MODEL DSEE EPDM EXPANSION JOINT, DRILLED BOLT HOLES		
DRAWN BY: DKISH		DATE: 1/24/2017
APPROVED: _____		DATE: _____
SCALE: N/A	DRAWING NUMBER: DSEE-2	

**CONTROL UNIT SELECTION CHART / DIMENSIONS
FOR MODEL DS (DOUBLESFERES) ONLY**

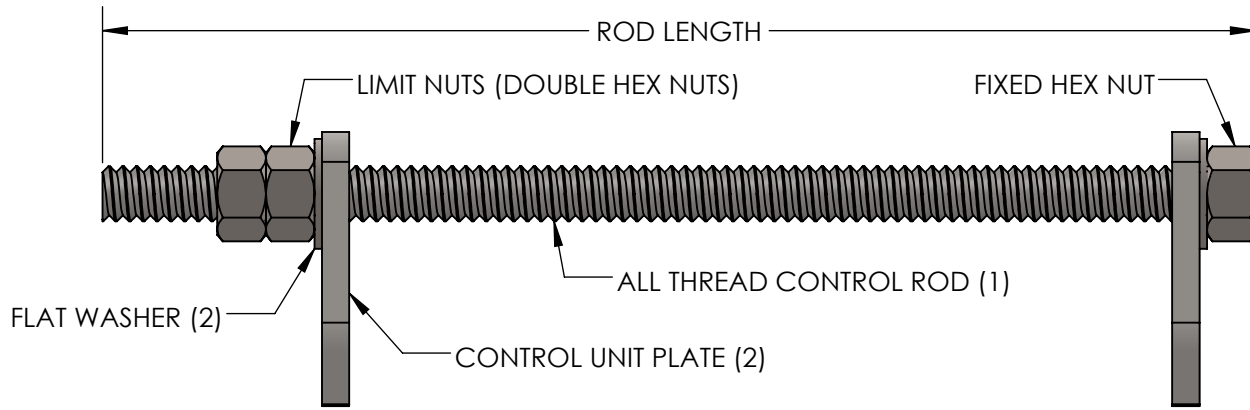

CONSULT FACTORY FOR NUMBER OF CONTROL UNITS REQUIRED

PIPE SIZE	ROD TYPE	ROD THICKNESS	ROD LENGTH	PLATE TYPE	PLATE THICKNESS	PLATE OD
1-1/4"	GUSRD058X140	5/8"	14"	GUSPLT01	3/8"	8-3/4"
1-1/2"	GUSRD058X140	5/8"	14"	GUSPLT01	3/8"	9-1/8"
2"	GUSRD058X140	5/8"	14"	GUSPLT0204	3/8"	10-1/8"
2-1/2"	GUSRD058X140	5/8"	14"	GUSPLT2503	3/8"	11-1/8"
3"	GUSRD058X140	5/8"	14"	GUSPLT2503	3/8"	11-5/8"
4"	GUSRD058X160	5/8"	16"	GUSPLT0204	3/8"	13-1/8"
5"	GUSRD058X160	5/8"	16"	GUSPLT0506	1/2"	14-1/8"
6"	GUSRD058X160	5/8"	16"	GUSPLT0506	1/2"	15-1/8"
8"	GUSRD100X210	1"	21"	GUSPLT0800	1/2"	19-1/8"
10"	GUSRD100X250	1"	25"	GUSPLT1012	3/4"	21-5/8"
12"	GUSRD100X250	1"	25"	GUSPLT1012	3/4"	24-5/8"
14"	GUSRD100X250	1"	25"	GUSPLT1400	3/4"	26-5/8"
16"	GUSRD125X295	1-1/4"	29-1/2"	GUSPLT1600	3/4"	30-1/8"
18"	GUSRD125X295	1-1/4"	29-1/2"	GUSPLT1800	3/4"	31-5/8"
20"	GUSRD125X295	1-1/4"	29-1/2"	GUSPLT2000	3/4"	34-1/8"
24"	GUSRD125X295	1-1/4"	29-1/2"	GUSPLT2400	1"	38-5/8"

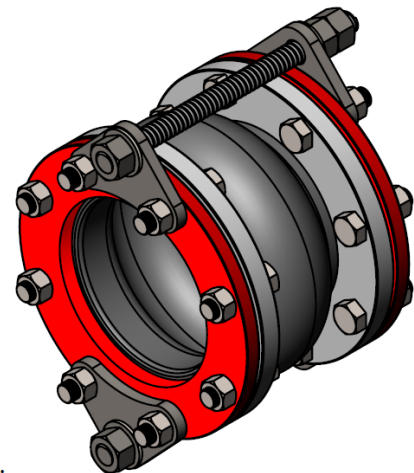
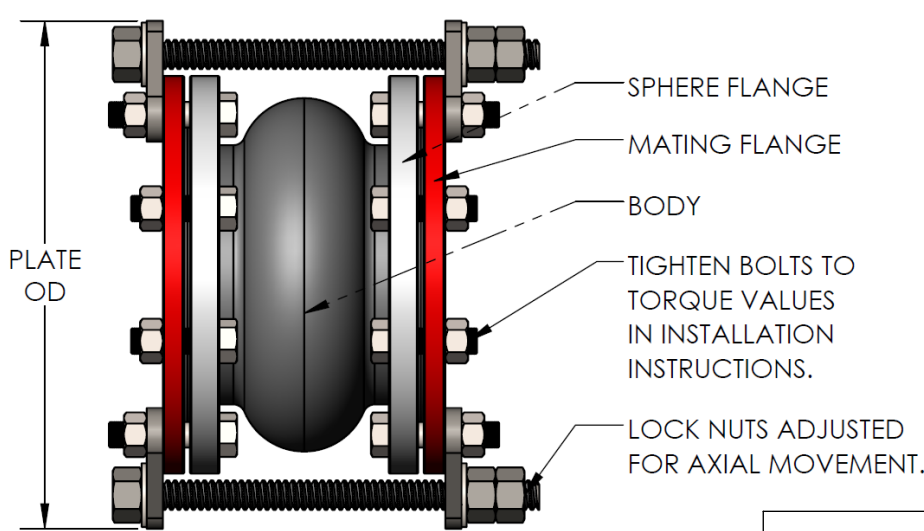

CUSTOMER: _____

PROJECT: _____

ENGINEER: _____

Metraflex
for pipes in motion

2323 W. HUBBARD ST.
CHICAGO, IL 60612
TEL: 312-738-3800
FAX: 312-738-0415
WWW.METRAFLEX.COM

CONTROL UNITS FOR DOUBLESFERES

DRAWN BY: JULIANH	DATE: 12/11/2024
APPROVED:	DATE:
SCALE: N/A	DRAWING NUMBER: CONTROLUNIT-DS-3