

MODULAR RISER GUIDE™

VIBRATION ISOLATION PIPE GUIDE FOR RISERS

**Now isolate 52%
of transmitted
noise with the
compact Modular
Riser Guide**

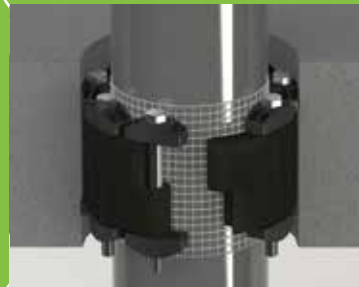

**Turns holes into
pipe guides!**

Metraflex
for pipes in motion

www.metraflex.com

The Modular Riser Guide

In-the-hole pipe guide isolates 52% of transmitted noise

Unique slide surface allows unlimited axial movement

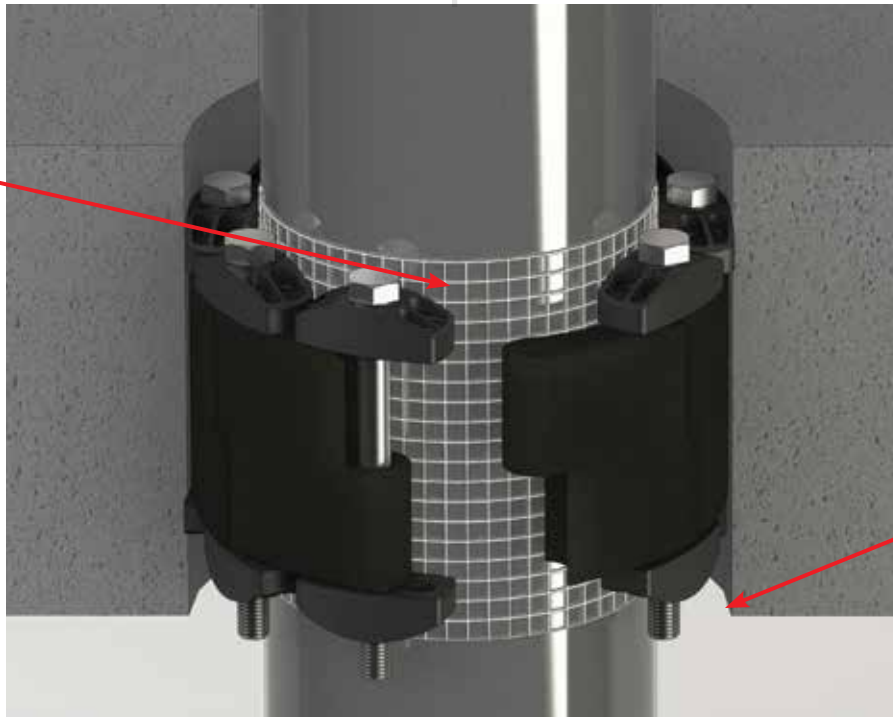

Core-drilled or sleeved hole

Unlimited axial movement in the tightest spaces!

The redesigned Modular Riser Guide allows unlimited axial pipe movement. It quickly fastens around the pipe, fills the annular gap and can be installed in a riser.

Its modular design allows for a quick installation in very tight spaces by utilizing existing floor penetrations.

Ease of installation - no more welding or drilling through concrete – simply use the existing hole, wrap the modular belt with a friction reducing layer around the pipe, fasten a few bolts, and walk away!

The lateral stability protects the expansion joint against squirm.

Creating a water resistant seal for temperature applications up to 250°F, the Modular Riser Guide can guide any size pipe.

Features/Benefits

- Unlimited axial movement
- Faster install time
- No more welding or fastening to external surfaces
- Vibration dampening
- Noise isolation
- Install around any round pipe

Independent testing shows the rubber sealing element eliminates up to 52% vibration, and protects the building's occupants from the unwanted noise & vibration.



Metraflex
for pipes in motion

2323 W. HUBBARD ST • CHICAGO, IL 60612 • 800-621-4347 • 312-738-3800 • FAX 312-738-0415 • www.metraflex.com